



SURGE ACTUATORS

HYDRAULIC SURGE BRAKE ACTUATION

INSTALLATION INSTRUCTIONS

Dexter DX7.5 (Formerly Model 750E) Brake Actuator

#	TDE Part #	DX Part #	Description
1A	70519K - Disc	K68-525-20	Brake Master Cylinder Kit: master cylinder and cap, 4 mounting screws with washers, 2 rollers with matching nuts and bolts
	70519KD - Drum	K68-525-00	
1B	11286	054-240-00	Disc Brake Solenoid - used with Disc Brake Actuators
2	70412	068-563-00	Latch Kit Assembly, with Drop-N-Go™ Coupler, (for serial numbers 17927 and above)
3	50317	068-738-10	Emergency Stop Cable (E-stop/Breakaway)
4	50301	074-477-00	Safety Cable with stainless steel pin - Includes mounting screw
5	70462K	K68-524-00	Actuator Covers, Includes: front and rear cover plates and 4 mounting screws
6	48986A	068-572-00	Master Cylinder Fill Cap with internal bladder, 2.25" Opening (E-Models)
7	48844	046-259-00	Safety Spring with two mounting screws

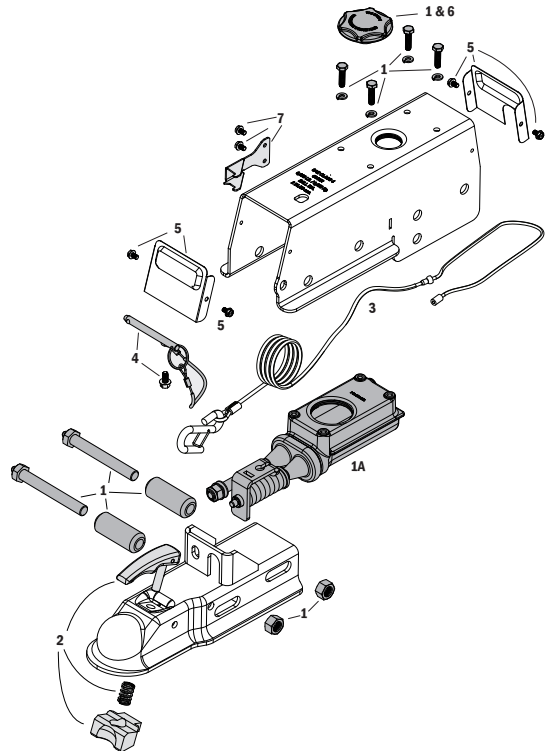

IMPORTANT: READ AND UNDERSTAND THE ENTIRE INSTRUCTION/ASSEMBLY PROCEDURE BEFORE INSTALLATION.

The DX7.5 works by the “surge” or “push” of the trailer toward the tow vehicle. This automatically synchronizes the trailer brakes with the tow vehicle axle brakes. When the trailer pushes against the tow vehicle, the actuator telescopes together and applies the force to the master cylinder, supplying hydraulic pressure to the brakes. The built in dampening shock absorber retards the telescoping shock against the hitch ball.

CAUTION

Brake laws sometimes are minimum standards and you may wish to add additional brakes to your trailer. Read your tow vehicles owner’s manual on towing capacity and other towing recommendations before installing brakes or this actuator.

Read your vehicle’s owner manual on towing capacity and other towing recommendations before installing brakes or this actuator. The DX7.5 Actuator is completely assembled and ready to bolt into place, if not already installed. Manufactured for tongue sizes: 3”x 3”, 3”x 4” & 3”x 5”.

1. Bolt the actuator to the tongue using grade 5 bolts 1/2 inch in diameter, 4 inches long. Lightweight tongues, less than 11 gauge, require spacer tubes inside the tongue for reinforcement. Attachment strength should equal or exceed 1-1/2 times trailer G.V.W.R.

2. Hydraulic brake lines should be installed on the trailer as described in the installation manual supplied with the brakes. Note: Some disc brakes require the use of flexible brake lines at the connection point on the brake caliper. Follow brake manufacturer instructions.

CAUTION

- **DO NOT REUSE BRAKE FLUID. Always use fresh DOT 3 fluid from a fresh container. Failure to maintain proper levels of fluid in the reservoir will cause brake failure.**
- **ONLY USE DOT 3 or 4 brake fluid. DO NOT USE OF DOT 5 BRAKE FLUID. DOT 5 brake fluid will cause damage to internal parts that can result in loss of brake power.**

3. Use a pressure type brake bleeder to bleed brakes following manufacturer’s directions. Or, manually bleed the brakes following the instructions on page 3. Check with your state motor vehicle department for laws concerning minimum trailer brake requirements. Some states may require brakes on all axles.
4. Road test trailer a short distance to activate the actuator several times. Check fluid level again. Remember, low brake fluid levels will result in hitch ball knocking.

CAUTION

AVOID sharp turns, which can cause the actuator to bind or jackknife against the tow vehicle or cause a bend in the tongue. Either can damage the actuator causing brake failure. AVOID towing trailer across large bumps or dips that may over stress the connection between the trailer and tow vehicle, as this could result in damage to the actuator.

RATED CAPACITY: Maximum Actuator Capacity: 7500 lbs. Gross Load, 750 lbs. Maximum Tongue Load.

The actual in-service rating is limited to that of the ball and hitch being used or the trailer manufacturer's G.V.W.R. shown on the certification label, whichever is lower (Note: G.V.W.R. is the Gross Vehicle Weight Rating which includes the trailer and the load weight as a Total Gross Weight).

CAUTION

A minimum of 5% tongue weight and a maximum 10% tongue weight of the trailer G.V.W.R must be located on the hitch ball. The Trailer tongue should be parallel to the ground. Too much weight can cause premature brake actuation and loss of control of the towing vehicle. Too little tongue weight can cause the trailer to fishtail, resulting in loss of control of the tow vehicle and trailer (total trailer weight G.V.W.R. includes weight of the trailer plus load).

Hitching The Trailer

1. The vehicle, towing hitch and ball must have a rating equal to or greater than trailer G.V.W.R..
2. DX7.5 will accept 2" ball only. Trailer balls larger than 2.00" (50mm) or out of round will not fit the coupler or may result in coupler failure. Balls smaller than 1.95" can cause shock loading and sudden disconnection. Make certain ball latch is in correct position to retain the hitch ball. Push latch until safety latch engages plate below latch. Insert safety pin into forward hole as a safety lock for the hitch ball coupler prior to towing. Do not tow trailer if coupler is damaged.

CAUTION

- **Failure to install the hitch pin before towing can result in accidental opening of the coupler hitch latch which can lead to the trailer coming off of the hitch ball causing serious damage, injury or death. If pin will not fit into the front lower hole, the coupler is not attached properly. Reset coupler on hitch ball.**
- **A loose fit between the coupler and hitch ball can cause the actuator and hitch ball to separate, causing serious damage, injury or death. Check coupler every time prior to towing and at each stop on long trips. Always make certain that coupler latch safety pin is securely installed into coupler latch.**

3. Connect safety cables or chains using crossed pattern under tongue, or follow trailer manufacturer's directions.

CAUTION

Never allow the coupler latch safety pin to remain in the reverse lockout position hole. After reverse maneuvering, always insert coupler latch safety pin back into coupler latch. FAILURE TO REMOVE SAFETY PIN FROM REVERSE LOCK OUT POSITION HOLE WILL PREVENT FORWARD MOVEMENT BREAKING WHICH CAN RESULT IN SERIOUS PROPERTY DAMAGE, INJURY OR DEATH.

4. Connect actuator breakaway cable S-hook to the tow vehicle only. Do not connect S-hook to the safety cables or chains.
5. The breakaway system is designed to only operate after the trailer detaches from the tow vehicle and the safety chains have failed. Do not use the breakaway as a parking brake.
6. If the breakaway is accidentally applied, insert a flat bladed screwdriver into the spring clip on the side of the actuator and pry sideways pressure to release.

CAUTION

- **The breakaway system is not designed to operate if the trailer does not separate completely from the tow vehicle, or if the tongue goes under the rear of the tow vehicle.**
- **In the event that the breakaway system is used, check all system components for proper working order. Replace any damaged parts with genuine Dexter parts only.**
- **When resetting the breakaway system keep hands and fingers clear as you re-set the mechanism, hydraulic pressure held in the system may cause the assembly to snap back suddenly.**

7. Any control devices that restrict operation of the actuator cannot be used. This includes certain sway control devices. The actuator must be free to telescope in response to braking requirements.
8. Equalizing or weight distributing hitches may be used, that are designed to use with surge brake actuators, allow six to eight inches free chain length.

CAUTION

Failure to remove pin will also prevent forward braking. Pin must be in the lower, forward hole as a safety lock for the hitch ball coupler latch when towing at all times.

9. The actuator is designed for use with Free-Backing trailer brakes. To block braking action, (in order to back up) with other types of brakes including disc brakes, use an electric solenoid. Place the safety pin in the hole on the side of the actuator housing to block movement of the actuator for reverse movement without brakes.

Directions Vehicle Wiring - Brake Solenoid

1. Disconnect trailer hitch and any wiring connectors from the vehicle.
2. Connect a 14 gauge wire to the backup (reverse) light wire of the vehicle. This wire should be of sufficient length to attach to the existing vehicle/trailer wire receptacle. The end of this wire will require a female end that will match the solenoid male connector wire. Your vehicle may have a 5 wire connection for this purpose.
3. For ease of use, tape or band the end of the reverse light wire to the vehicle's trailer electrical connector.

Maintenance

CAUTION

The exterior of the actuator and brakes should always be rinsed with fresh water after use in corrosive conditions. Before storing trailer, clean brakes and repack the bearings. Failure to properly maintain the actuator could cause serious damage, injury or death.

1. Always check the brake fluid reservoir before using trailer. Make sure it is at least half full. If not, re-fill to $\frac{3}{8}$ " below the top of the reservoir with DOT 3 brake fluid. Do not use DOT 5 brake fluid. Check for leaks and repair as required. Never reuse brake fluid.
2. To extend coupler and ball life, coat both with a thin coating of grease. This will also eliminate squeaking. Wipe clean and renew film each time trailer is used.
3. Examine the actuator for bent parts or wear each time the trailer is used. Replace parts as necessary.
4. There are no user adjustments on the actuator.
5. Actuator travel (shown by coupler roller path) over one inch indicates a need to adjust the brakes or add fluid to the reservoir or a need to bleed the brakes and check connections for leaks. Adjust per instructions found in brake installation manual. In general, back-off adjusters on drum brakes from locked position, as required. Adjust Free-Backing brakes by rotating in forward direction only. Failure to adjust may result in loss of braking. Disc brakes do not require adjustment, check for pad wear.

Bleeding Instructions

1. To bleed master cylinder and brakes, install bleeder hose on first wheel cylinder to be bled; if tandem axle trailer, bleed closest axle first, and the closest brake on that axle first. Use a loose end of hose from the bleeder valve submerged in a glass container of brake fluid to observe bubbling (hose must be submerged into clean brake fluid to keep air from traveling back into the brake cylinder).
2. Pump master cylinder, keeping pressure, using a flat tip screwdriver (1A). Crack bleeder valve open and tighten. Repeat until there are no more air bubbles.
3. The screwdriver should be at the lowest angle possible to the actuator so that it slides in front of the e-stop bracket (See 1B).

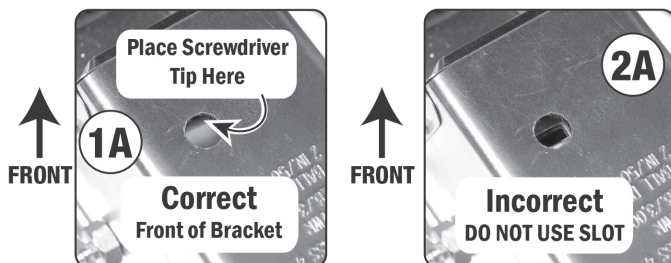
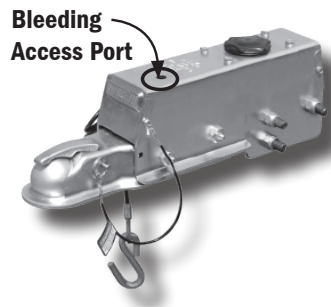

4. Screwdriver tip MUST BE IN FRONT of the e-stop bracket and NOT in the slot on the e-stop bracket (See 2A).

5. Push the screwdriver forward and back to pump the master cylinder. (See 2B).

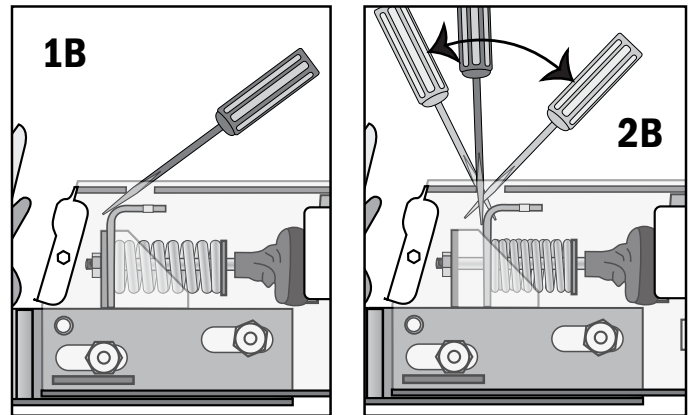

6. The bleeding operation for that brake is complete when bubbling stops. Be sure to tighten bleeder screw securely. Each wheel cylinder must be bled until all air is out of the lines. Replenish the brake fluid during the bleeding process so the level does not fall below half full level in the master cylinder reservoir.
7. When bleeding and testing is completed, make sure master cylinder is filled to $\frac{3}{8}$ " below the top of the reservoir and filler cap is securely in place.

Emergency Button Stop

Shown in normal operating position

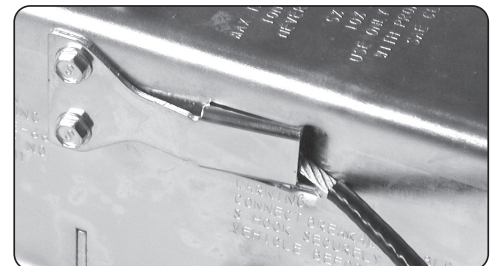

If button stop cable is showing DO NOT TOW TRAILER. Release emergency stop cable by prying spring out with a flat blade screw driver.

