

Master Cylinder Rebuild Kit for Model 660, 700/750 and 800/850 Actuators Part #70461K and #70462K

Tools Required:

- ✓ Wheel chocks to keep trailer from moving
- ✓ Jack stand to elevate trailer tongue
- ✓ 3mm or 1/8" hex wrench for top four (4) screws
- ✓ 10mm wrench for dampener rod
- ✓ 14mm wrench for dampener rod lock nut
- ✓ 9/16" for "zerc" end of pin/bolt
- ✓ 3/4" or 19mm for jam nuts on the pins/bolts
- ✓ Rags or old towel to catch brake fluid
- ✓ Inch pound torque wrench
- ✓ Permatex 51845 or equivalent

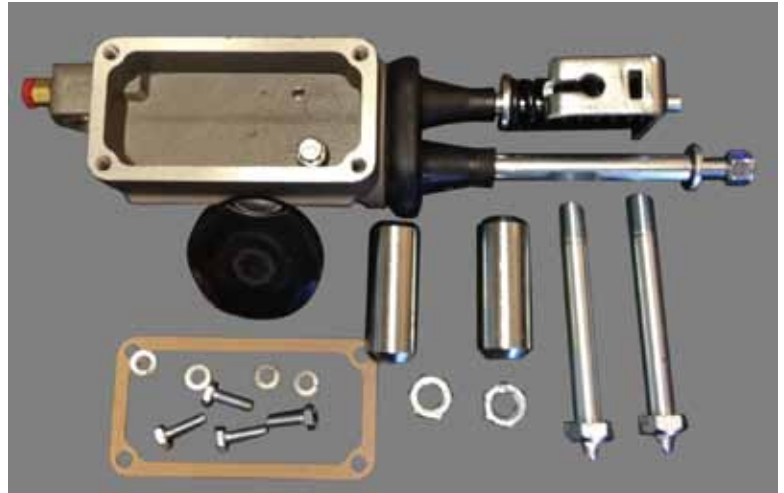

Remove Old Master Cylinder:

1. Secure the trailer on a level spot. Block the wheels and elevate the trailer tongue to be able to work on the actuator. Use old towels or rags under the actuator to catch brake fluid that might spill.
2. Remove the "guts" of the actuator from the housing.
 - a. Remove the front and rear covers, two small bolts each.
 - b. Remove the brake line from the rear of the master cylinder. Elevate the end of the hose to keep brake fluid from draining out of the brake lines.
 - c. Remove the bolts that attach the actuator to the trailer tongue.
 - d. Place the actuator on a flat clean working area to dis-assemble the actuator.
 - e. Remove the two small bolts holding the safety cable spring clip on the "passenger" side of the actuator housing.
 - f. Remove the four stainless steel screws on top of the actuator holding the master cylinder in place.
 - g. Remove the two bolts that have zerc fittings on one end. The kit has new replacement bolts.
 - h. Slide the coupler/master cylinder assembly out of the housing. The master cylinder uses the housing as the cover for the reservoir. It may be necessary to "wiggle" the master cylinder to release it from the housing.
3. Remove the safety cable from the "L" bracket on the master cylinder.
4. Using a 10mm wrench for the rod, and a 14mm wrench for the nut, remove the lock nut holding the dampener rod to the coupler housing.
5. Slide the master cylinder away from the coupler.

Installing New Master Cylinder:

1. Now would be a good time to clean the coupler and the actuator housing of road grime and dirt.
2. Your kit contains parts to replace the gasket, rollers, pins/bolts and the top SS screws. Do not reuse old parts where new parts are available in the kit.
3. If your old master cylinder has a disc brake solenoid you need to remove and reinstall on your new master cylinder.
4. Insert the new rollers into the coupler body. This must be done before reassembly of the master cylinder to the coupler.
5. Re-connect the emergency cable to the "L" bracket and wrap the steel cable around the master cylinder at the top.

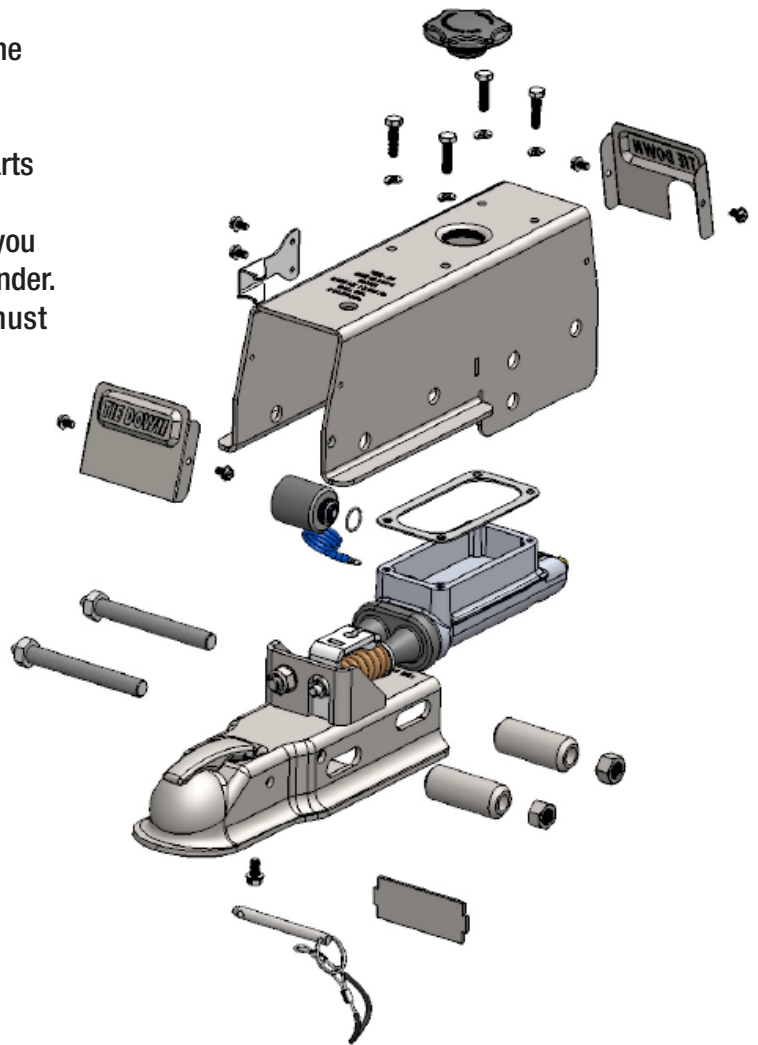

6. Place one 1/2" flat washer on the dampener rod. Slide the master cylinder into the coupler so that the dampener rod goes into the hole in the plate. Place another flat washer on the dampener rod. While holding the dampener rod with a 10mm wrench, add the lock nut and turn the loc nut with a 14mm wrench until the rod is tight to the coupler plate.
7. Thoroughly clean the underside of the housing where the master cylinder will be attached. Surface must be smooth and clean for the gasket to seal properly.
8. Coat both sides of the gasket provided with a thin coat of Permatex 51845 or equivalent "gasket sealer". Be careful not to apply so much that it will fall into the master cylinder. "More is not better". Place the gasket on the master cylinder reservoir.
9. Slide the "new" assembly back into the housing.
10. Insert the new pins/bolts with the zerco's lining up the rollers with the holes in the housing.
11. Line up the master cylinder so that you can re-install the top four (4) SS screws into the master cylinder top plate. Use a Loc-Tite or similar coating to insure the screws stay in place. Torque to 150 INCH lbs. (not foot lbs, 150 INCH lbs is 12.5 foot lbs)
12. Tighten the jam nuts on the roller pins to a "just snug" position. Pins must be able to rotate.
13. Re-attach the flat spring on the E-stop cable. The "ball" attachment on the cable must be to the inside of the housing
14. Re-install housing/actuator on trailer tongue if required
15. Re-install brake line to master cylinder
16. Bleed brakes using instructions from brakes or actuator.